



Product Overview:

The WEP-120 wide belt elevating prefeeder is specially designed to handle large parts. Two independently controlled variable speed drives ensure gentle product metering. Designed for floor level parts loading, the 120 ft³ capacity hopper delivers product at an average belt speed of 23 feet per minute. The cleated elevator belt has a nominal cleat height of 4" and a cleat pitch of 12", allowing for maximum product loading. Note: Controllers and mechanical level sensors are not supplied with this unit.

Part Number	WE12022DSA	WE12022ASA
Motor Style	DC	AC
Motor Voltage	90V	230/460V
Horsepower (Horizontal)	1/2hp	1/2hp
Horsepower (Elevator)	1/2hp	1/2hp
Total Equipment Weight	2500 lbs.	1134 kg
Hopper Capacity	120 ft ³	3400 liters

Standard Features:

- Stainless steel construction
- Sensor controlled dual belt metering system
- Horizontal belt is FDA/USDA approved white buna-n/polyester polyflake endless belting
- Elevator belt is FDA/USDA approved white 1-ply solid woven polyester fabric with .156" thick white PVC coating and PVC cleats

Available Options:

- Elevator extensions*
- Continuous welded hopper seams
- Elevator/Hopper covers
- Washdown motor
- NEMA 1 encased controller
- Clean out doors
- Casters

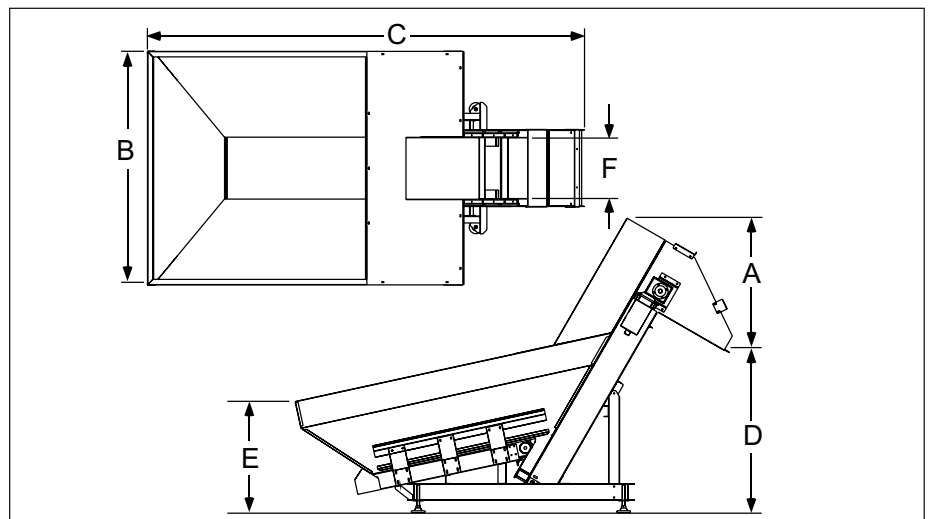

Product Specifications		ANSI	Metric
A	Discharge Chute Height	40"	1016mm
B	Overall Width	63"	1600mm
C	Overall Length	130"	3302mm
D	Dump Height (Adjustable)	58"	1473mm
E	Hopper Load Height	35.25"	895mm
F	Belt Width (Elevator)	22"	559mm

* It is strongly recommended that the frame of the prefeeder be reinforced and/or additionally supported for elevator extensions of 54" or greater.

Headquarters
13129 Airpark Dr.
Suite 120
Elkwood, VA 22718
540.829.2564 t
800.368.3582 t
540.829.1726 f

Sales Office
1445 Brookville Way
Suite F
Indianapolis, IN 46239
317.322.0754 t
800.368.3582 t
317.322.0794 f

Manufacturing Office
291 Dillard Road
Madison Heights, VA
24572
434.929.4746 t
800.543.0915 t
434.929.4959 f

www.ShibuyaHoppmann.com | sales@ShibuyaHoppmann.com

Shibuya Hoppmann Corporation strives to improve its products and reserves the right to change or discontinue specifications & designs shown in this brochure without notice and without incurring obligation. Revised: 12/11.