



Product Overview:

Shibuya Hoppmann's WB-6 prefeeder is specially designed to handle fragile parts. Two independent variable speed drives and a standard level sensor ensures gentle product metering. Product drops from the upper belt to the lower belt where it is pulled away at a faster rate to assist in part separation and de-tangling. Note: Controllers and mechanical level sensors are not supplied with this unit.

Part Number	WB06XXXDSA	WB06XXXASA
Motor Style	DC	AC
Motor Voltage	90V	220/380V
Upper Belt Horsepower	1/8hp	1/2hp
Lower Belt Horsepower	1/30hp	1/4hp
Total Equipment Weight	650 lbs.	295 kg
Supply Hopper Capacity	6 ft ³	170 liters

Standard Features:

- Stainless steel construction
- Adjustable feed angle
- Sensor controlled dual belt metering system
- FDA/USDA approved white buna-n/ polyester polyflake endless belting (upper belt)
- Durable reinforced black neoprene belt with fiberglass cord (lower belt)

Available Options:

- Continuous welded hopper seams
- Washdown motor
- NEMA 1 encased controller
- Hopper covers
- Casters

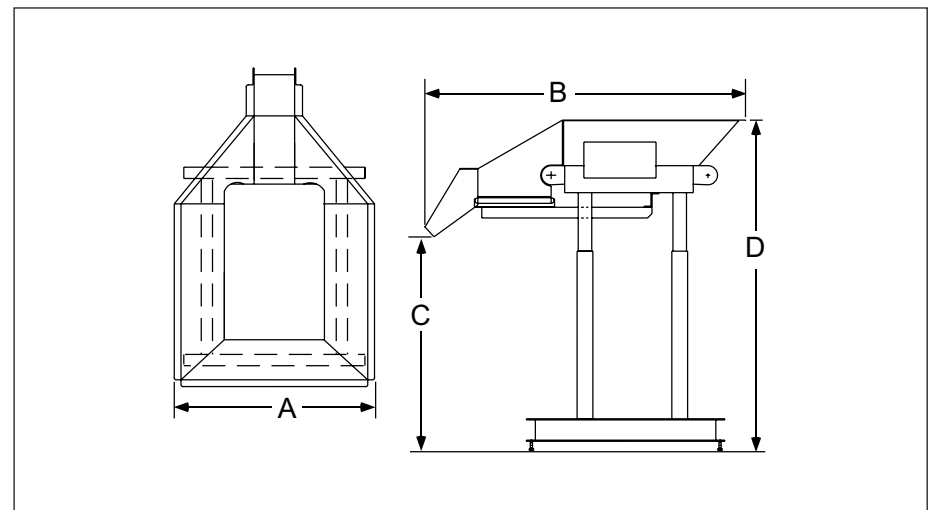

Product Specifications		ANSI	Metric
A	Overall Width	51"	1295mm
B	Overall Length	72"	1829mm
C	Dump Height (Adjustable)	48" ± 10"	1219 ± 254mm
D	Load Height (Adjustable)	74" ± 10"	1880 ± 254mm
E	Angle of Feed	0° - 11°	0° - 11°

Headquarters
13129 Airpark Dr.
Suite 120
Elkwood, VA 22718
540.829.2564 t
800.368.3582 t
540.829.1726 f

Sales Office
1445 Brookville Way
Suite F
Indianapolis, IN 46239
317.322.0754 t
800.368.3582 t
317.322.0794 f

Manufacturing Office
291 Dillard Road
Madison Heights, VA
24572
434.929.4746 t
800.543.0915 t
434.929.4959 f

www.ShibuyaHoppmann.com | sales@ShibuyaHoppmann.com

Shibuya Hoppmann Corporation strives to improve its products and reserves the right to change or discontinue specifications & designs shown in this brochure without notice and without incurring obligation. Revised: 12/11.