

Product Overview:

Shibuya Hoppmann's standard TP-30 trough prefeeder is specially designed for handling a variety of fragile parts. The prefeeder features protective sides, food grade belt and variable speed control. Typical applications include those in which the parts may have a tendency to nest or tangle with each other, or may become damaged by a cleated belt style prefeeder. Note: Controllers and mechanical level sensors are not supplied with this unit.

Part Number	TPXX30XDSA	TPXX30XASA
Motor Style	DC	AC
Motor Voltage	90V	230/460V
Horsepower	1/2hp	250w
Total Equipment Weight	450 lbs.	204 kg
Hopper Capacity	30 ft ³	850 liters

Standard Features:

- Stainless steel construction
- DC variable speed motor
- Belting is FDA/USDA approved white 1-ply solid woven polyester fabric with .156" thick white PVC coating and PVC cleats

Available Options:

- Washdown motor
- NEMA 1 encased controller
- Hopper covers
- Casters

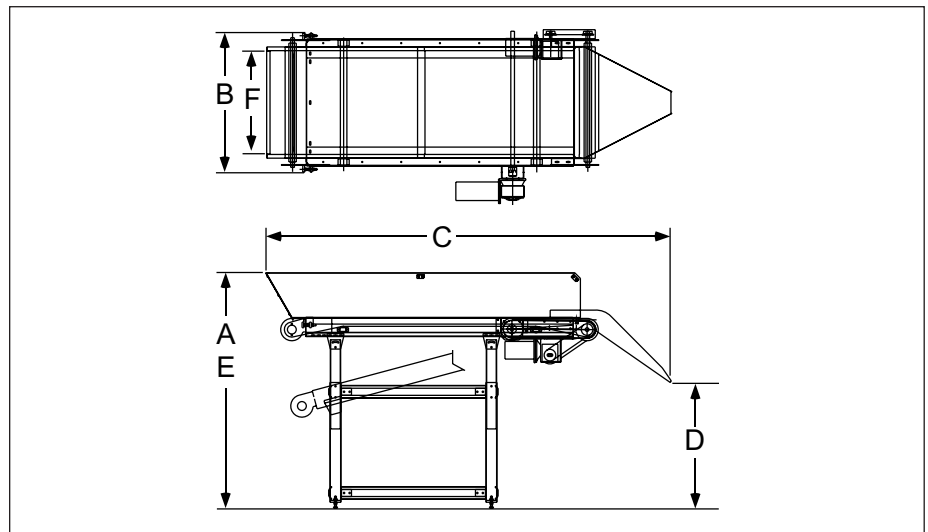

Product Specifications		ANSI	Metric
A	Overall Height	63.5" ± 7.5"	1575 ± 190mm
B	Overall Width	47"	940mm
C	Overall Length	109"	2667mm
D	Dump Height (Adjustable)	33.5" ± 7.5"	851 ± 190mm
E	Hopper Load Height (Adjustable)	63.5" ± 7.5"	1613 ± 190mm
F	Belt Width	30"	762mm

Headquarters
13129 Airpark Dr.
Suite 120
Elkwood, VA 22718
540.829.2564 t
800.368.3582 t
540.829.1726 f

Sales Office
1445 Brookville Way
Suite F
Indianapolis, IN 46239
317.322.0754 t
800.368.3582 t
317.322.0794 f

Manufacturing Office
291 Dillard Road
Madison Heights, VA
24572
434.929.4746 t
800.543.0915 t
434.929.4959 f

www.ShibuyaHoppmann.com | sales@ShibuyaHoppmann.com

Shibuya Hoppmann Corporation strives to improve its products and reserves the right to change or discontinue specifications & designs shown in this brochure without notice and without incurring obligation. Revised: 12/11.