



**Product Overview:**

Shibuya Hoppmann's standard LB-03 and LB-06 overhead prefeeders are designed to handle small to medium sized parts and are engineered to interface directly with smaller style parts feeders. A variable speed motor drives the belt at a speed of 23.00 inches per minute. Note: Controllers and mechanical level sensors are not supplied with this unit.

Part Number	LB03XXXDSA	LB03XXXASA
Motor Style	DC	AC
Motor Voltage	90V	208-230/460V
Horsepower	1/30hp	1/8hp
Total Equipment Weight	110 lbs.	50 kg
Hopper Capacity (LB-3)	3 ft <sup>3</sup>	85 liters
Hopper Capacity (LB-6)	6 ft <sup>3</sup>	170 liters

**Standard Features:**

- Stainless steel construction
- Durable reinforced black neoprene belt with fiberglass cord
- Feeder mounting brackets

**Available Options:**

- Continuous welded seams
- Hopper covers
- Continuous welded hopper seams  
Tan neoprene USDA/FDA dry contact food belt with fiberglass cord (Food Grade Unit: LB03XXXDFA and LB03XXXAFA)
- NEMA 1 encased controller

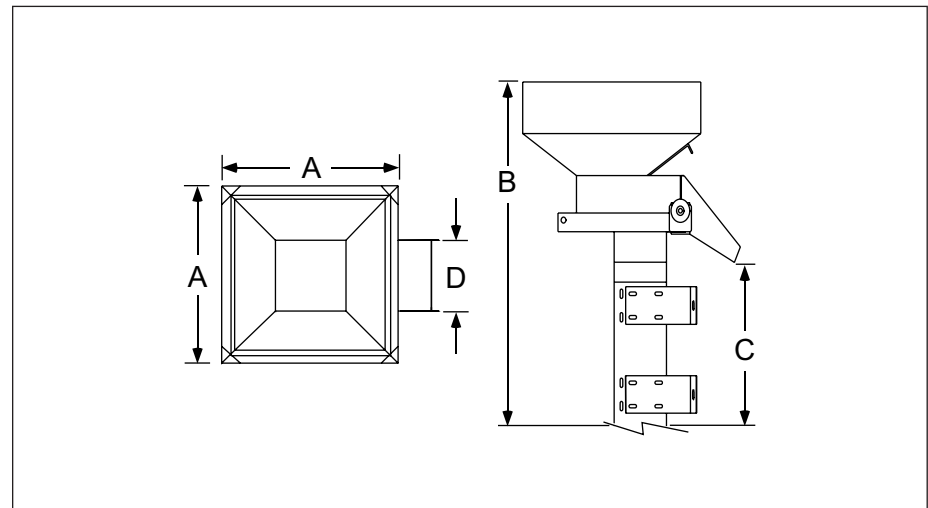

Product Specifications		ANSI	Metric
A	Hopper Width and Length	24" x 24"	610 x 610mm
B	Overall Height – LB-03	37"	940mm
B	Overall Height – LB-06	47.5"	1207mm
C	Discharge Height	17.5"	445mm
D	Belt Width	9.9"	252mm