

**Product Overview:**

Shibuya Hoppmann's standard LB-01 overhead prefeeder is specially designed to handle small parts and is engineered to interface directly with smaller style parts feeders. A variable speed motor drives the belt at a speed of 23.00 inches per minute. Note: Controllers are not supplied with this unit.

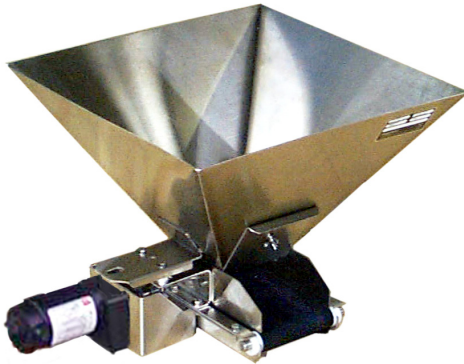

Part Number	LB01XXXDSA
Motor Style	DC
Motor Voltage	90V
Horsepower	1/30hp
Total Equipment Weight	35 lbs. / 16 kg
Hopper Capacity	1 ft <sup>3</sup> / 28.32 liters

**Standard Features:**

- Stainless steel construction
- Durable reinforced black neoprene belt with fiberglass cord
- Feeder mounting brackets

**Available Options:**

- Continuous welded seams
- Hopper covers
- Tan neoprene USDA/FDA dry contact food belt with fiberglass cord (Food Grade Unit: LB01XXXDFA)
- NEMA 1 encased controller

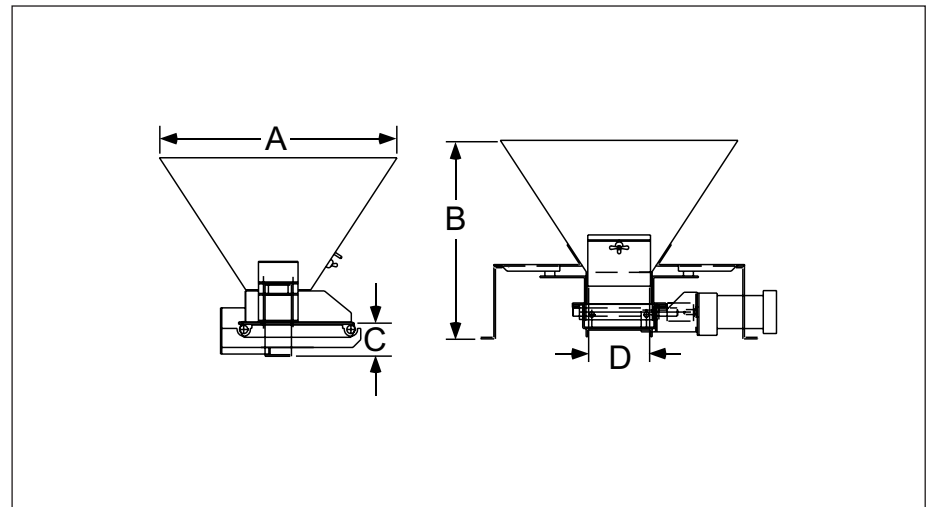

Product Specifications		ANSI	Metric
A	Hopper Width and Length	18" x 18"	457 x 457mm
B	Overall Height	15.25"	387mm
C	Discharge Height	2" ± 1"	51mm ± 25mm
D	Belt Width	5"	127mm

**Headquarters**  
13129 Airpark Dr.  
Suite 120  
Elkwood, VA 22718  
540.829.2564 t  
800.368.3582 t  
540.829.1726 f

**Sales Office**  
1445 Brookville Way  
Suite F  
Indianapolis, IN 46239  
317.322.0754 t  
800.368.3582 t  
317.322.0794 f

**Manufacturing Office**  
291 Dillard Road  
Madison Heights, VA  
24572  
434.929.4746 t  
800.543.0915 t  
434.929.4959 f

[www.ShibuyaHoppmann.com](http://www.ShibuyaHoppmann.com) | [sales@ShibuyaHoppmann.com](mailto:sales@ShibuyaHoppmann.com)

Shibuya Hoppmann Corporation strives to improve its products and reserves the right to change or discontinue specifications & designs shown in this brochure without notice and without incurring obligation. Revised: 12/11.