



Product Overview:

Shibuya Hoppmann's standard FT-60 rigid disc centrifugal feeder is designed to feed a variety of products with its unique bowl design. Product is metered into the bowl and brought out to the bowl rim where a series of qualifiers gently orient the part for transfer to various downstream inline devices.

Part Number	FT601RLDSA	FT601RLASA
Motor Style	DC	AC
Motor Voltage	90V	208-230/460V
Horsepower	3/4hp	3/4hp
Total Equipment Weight	1400 lbs.	635 kg

Standard Features:

- All stainless steel exterior construction
- FDA approved ABS vacuum formed disc
- Teflon hard-coated finished aluminum bowl

Available Options:

- Polycarbonate covers
- Dual motor drive system
- Washdown motor(s)
- NEMA 1 encased controller

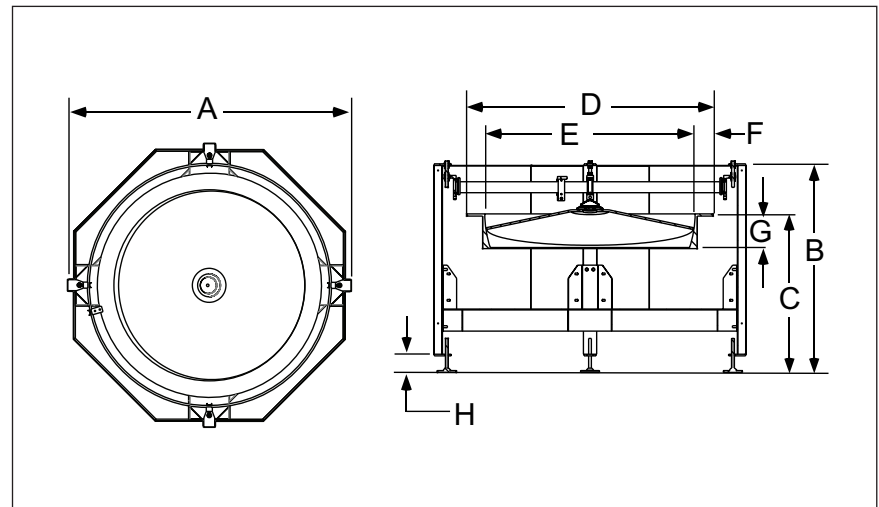

Required Accessories:	
Clockwise: Backup Ring	BUCWFT60SU
Counter-Clockwise: Backup Ring	BUCCT60SU

Product Specifications		ANSI	Metric
A	Outside Diameter	85"	2159mm
B	Frame Height	47" ± 1.5"	1194 ± 40mm
C	Discharge Height	36" ± 2"	914 ± 51mm
D	Bowl Outside Diameter	70"	1778mm
E	Bowl Inside Diameter	60"	1524mm
F	Rim Width	5"	127mm
G	Bowl Depth	9.13"	232mm
H	Level Foot Adjustment	5" ± 2.5"	127 ± 64mm

Headquarters
13129 Airpark Dr.
Suite 120
Elkwood, VA 22718
540.829.2564 t
800.368.3582 t
540.829.1726 f

Sales Office
1445 Brookville Way
Suite F
Indianapolis, IN 46239
317.322.0754 t
800.368.3582 t
317.322.0794 f

Manufacturing Office
291 Dillard Road
Madison Heights, VA
24572
434.929.4746 t
800.543.0915 t
434.929.4959 f

www.ShibuyaHoppmann.com | sales@ShibuyaHoppmann.com

Shibuya Hoppmann Corporation strives to improve its products and reserves the right to change or discontinue specifications & designs shown in this brochure without notice and without incurring obligation. Revised: 12/11.