



**Product Overview:**

The EP-35/EP-50 elevating prefeeder is designed to handle a variety of large, lightweight parts. Its 35 ft<sup>3</sup> capacity hopper delivers product at an average belt speed of 23 feet per minute. The cleated elevator belt has a nominal cleat height of 3.00" and a cleat pitch of 12.00" allowing for maximum product loading. A heavy duty variable speed motor helps to ensure proper product metering. Note: Controllers and mechanical level sensors are not supplied with this unit.

Part Number	EP3518XDSA	EP3518XASA
Motor Style	DC	AC
Motor Voltage	90V	230/460V
Horsepower	1/2hp	373w
Total Equipment Weight	1200 lbs.	544 kg
Hopper Capacity (EP-35/EP-50)	35 ft <sup>3</sup> / 50 ft <sup>3</sup>	991 / 1416 liters

**Standard Features:**

- Stainless steel construction
- Belting is FDA/USDA approved white 1-ply solid woven polyester fabric with .156" thick white PVC coating and PVC cleats
- Hopper cleanout door

**Available Options:**

- Elevator extensions\*
- Hopper extension for 50 ft<sup>3</sup> capacity
- Continuous welded hopper seams
- Elevator/hopper covers
- Washdown motor
- NEMA 1 encased controller
- Casters

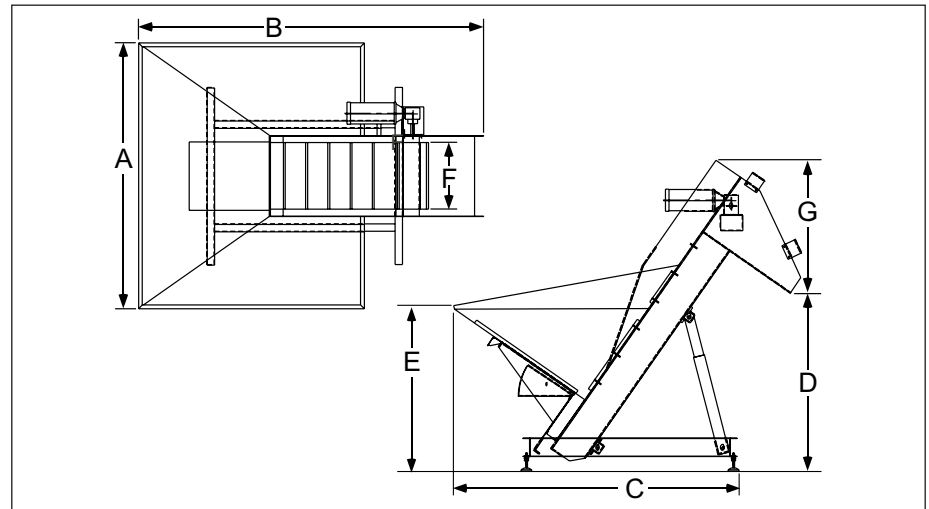

Product Specifications	ANSI	Metric
A Overall Width	72"	1829mm
B Overall Length	95"	2413mm
C Lower Chassis Footprint	76.62"	1947mm
D Dump Height (Adjustable)	45 - 58"	1143 - 1473mm
E Hopper Load Height (EP-35)	45"	1143mm
E Hopper Load Height (EP-50)	51"	1295mm
F Belt Width	18"	457mm
G Discharge Chute Height	25.5"	648mm

\* It is strongly recommended that the frame of the prefeeder be reinforced and/or additionally supported for elevator extensions of 54" or greater.

**Headquarters**  
13129 Airpark Dr.  
Suite 120  
Elkwood, VA 22718  
540.829.2564 t  
800.368.3582 t  
540.829.1726 f

**Sales Office**  
1445 Brookville Way  
Suite F  
Indianapolis, IN 46239  
317.322.0754 t  
800.368.3582 t  
317.322.0794 f

**Manufacturing Office**  
291 Dillard Road  
Madison Heights, VA  
24572  
434.929.4746 t  
800.543.0915 t  
434.929.4959 f

[www.ShibuyaHoppmann.com](http://www.ShibuyaHoppmann.com) | [sales@ShibuyaHoppmann.com](mailto:sales@ShibuyaHoppmann.com)

Shibuya Hoppmann Corporation strives to improve its products and reserves the right to change or discontinue specifications & designs shown in this brochure without notice and without incurring obligation. Revised: 12/11.