



Product Overview:

The EP-08/EP-15/EP-25 elevating prefeeder is designed to handle a variety of medium-sized, light weight parts. Its 8 ft³ capacity hopper delivers product at an average belt speed of 32'/minute. The cleated elevator belt has a nominal cleat height of 2.00" and a cleat pitch of 6.00" allowing for maximum product loading. A heavy duty variable speed motor helps to ensure proper product metering. Note: Controllers and mechanical level sensors are not supplied with this unit.

Part Number	EP0808XDSA	EP0808XASA
Motor Style	DC	AC
Motor Voltage	90V	230/460V
Horsepower	1/4hp	186w
Total Equipment Weight	720 lbs.	327 kg
Hopper Capacity (EP-08/EP-15/EP-25)	8 ft ³ / 15 ft ³ / 25 ft ³	227 / 425 / 708 liters

Standard Features:

- Stainless steel construction
- Belting is FDA/USDA approved white 1-ply solid woven polyester fabric with 1/16" thick white PVC coating and PVC cleats
- Hopper cleanout door
- One piece formed hopper (8 ft³ capacity)

Available Options:

- Elevator extensions*
- Hopper extension for 15 and 25 ft³ capacity
- Continuous welded hopper seams (EP-15/25)
- Elevator/hopper covers
- Washdown motor
- NEMA 1 encased controller
- Pneumatic hopper agitator (#AGITATOREP08)
- Casters

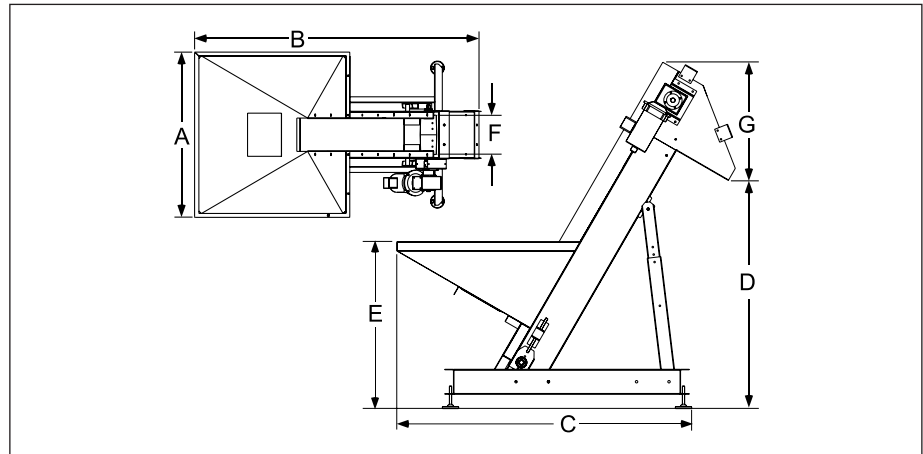

Product Specifications		ANSI	Metric
A	Overall Width	42"	1067mm
B	Overall Length	73"	1854mm
C	Lower Chassis Footprint	63.10"	1603mm
D	Dump Height (Adjustable)	42 - 53"	1067-1346mm
E	Hopper Load Height (EP-08)	34"	864mm
E	Hopper Load Height (EP-15)	42"	1067mm
E	Hopper Load Height (EP-25)	50"	1270mm
F	Belt Width	8"	203mm
G	Discharge Chute Height	25.5"	648mm

* It is strongly recommended that the frame of the prefeeder be reinforced and/or additionally supported for elevator extensions of 54" or greater.