



Product Overview:

The EP-04/EP-06 elevating prefeeder is designed to handle a variety of small, lightweight parts. Its 4 ft³ capacity hopper delivers product at an average belt speed of 35'/minute. The cleated elevator belt has a nominal cleat height of 1.50" and a cleat pitch of 6.00" allowing for maximum product loading. A heavy duty variable speed motor helps to ensure proper product metering. Note: Controllers and mechanical level sensors are not supplied with this unit.

Part Number	EP0406XDSA	EP0406XASA
Motor Style	DC	AC
Motor Voltage	130V	208-230/460V
Horsepower	1/5hp	1/4hp
Total Equipment Weight	250 lbs.	113.4 kg
Hopper Capacity (EP-04 / EP-06)	4 ft ³ / 6 ft ³	113 / 170 liters

Standard Features:

- Stainless steel construction
- Belting is FDA/USDA approved white 1-ply solid woven polyester fabric with .156" thick white PVC coating and PVC cleats

Available Options:

- Elevator extensions*
- Hopper extension for 6 ft³ capacity
- Continuous welded hopper seams
- Elevator/hopper covers
- Washdown motor
- NEMA 1 encased controller
- Pneumatic hopper agitator (#AGITATOREP04)
- Casters

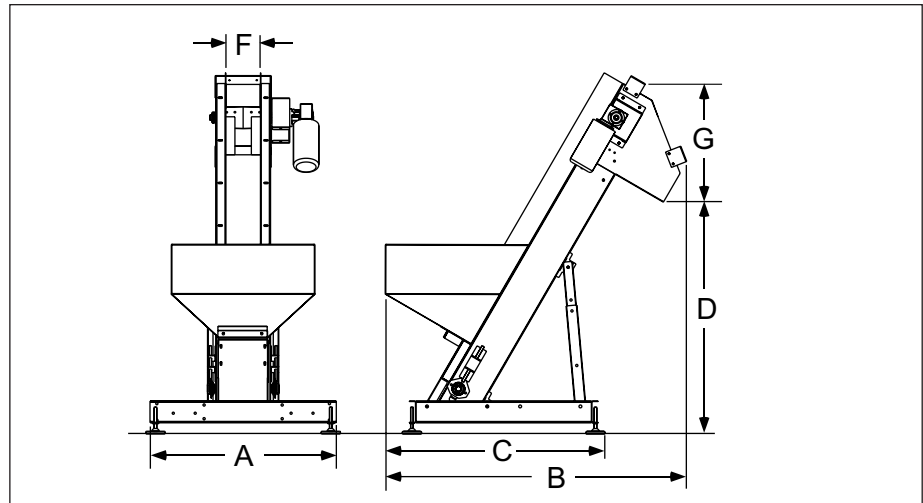

Product Specifications		ANSI	Metric
A	Overall Width	34"	864mm
B	Overall Length	55"	1397mm
C	Lower Chassis Footprint	39.13"	994mm
D	Dump Height (Adjustable)	40" - 46"	1016 - 1168mm
E	Hopper Load Height (EP-04)	34.5"	876mm
E	Hopper Load Height (EP-06)	39.5"	1003mm
F	Belt Width	6"	152mm
G	Discharge Chute Height	23.5"	597mm

* It is strongly recommended that the frame of the prefeeder be reinforced and/or additionally supported for elevator extensions of 54" or greater.

Headquarters
13129 Airpark Dr.
Suite 120
Elkwood, VA 22718
540.829.2564 t
800.368.3582 t
540.829.1726 f

Sales Office
1445 Brookville Way
Suite F
Indianapolis, IN 46239
317.322.0754 t
800.368.3582 t
317.322.0794 f

Manufacturing Office
291 Dillard Road
Madison Heights, VA
24572
434.929.4746 t
800.543.0915 t
434.929.4959 f

www.ShibuyaHoppmann.com | sales@ShibuyaHoppmann.com

Shibuya Hoppmann Corporation strives to improve its products and reserves the right to change or discontinue specifications & designs shown in this brochure without notice and without incurring obligation. Revised: 12/11.