



Product Overview:

The EH-08/15/25 horizontal discharge, elevating prefeeder is designed to handle medium-sized parts. Using a modular, plastic, cleated chain to vertically and horizontally transport parts, this prefeeder allows the discharge to be closer to the bowl, eliminating potential scuffing or scraping of parts while being able to reach over existing equipment. A heavy duty variable speed motor helps to ensure proper product metering. Note: Controllers and mechanical level sensors are not supplied with this unit.

Part Number	EH0808XDSA	EH0808XASA
Motor Style	DC	AC
Motor Voltage	90V	230/460V
Horsepower	1/3hp	1/3hp
Total Equipment Weight	1000 lbs.	454 kg
Hopper Capacity (EH-08/EH-15/EH-25)	8 ft ³ / 15 ft ³ / 25 ft ³	227 / 425 / 708 liters

Standard Features:

- Stainless steel construction
- Modular plastic chain
- Hopper cleanout door
- Elevator and hopper covers
- One piece formed hopper (8 ft³ capacity)

Available Options:

- Elevator extensions*
- Hopper extension for 15 and 25 ft³ capacity
- Continuous welded hopper seams (EH-15/25)
- Washdown motor
- NEMA 1 encased controller
- Pneumatic hopper agitator (#AGITATOREP08)
- Casters

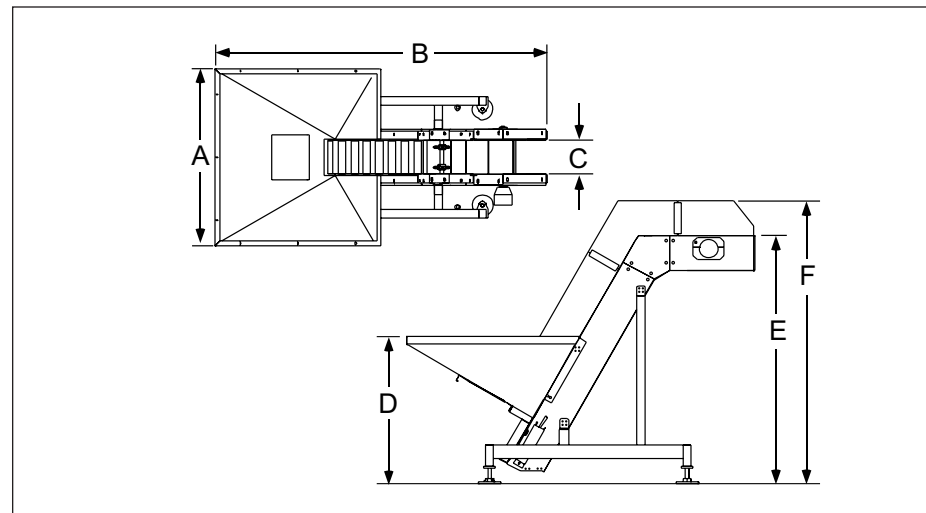

Product Specifications		ANSI	Metric
A	Overall Width	42.13"	1070mm
B	Overall Length	79.11"	2009mm
C	Modular Chain Width	9"	229mm
D	Discharge Height	48.38"	1229mm
E	Hopper Load Height - EH-08	33.56"	852mm
E	Hopper Load Height - EH-15	41"	1041mm
E	Hopper Load Height - EH-25	50"	1270mm
F	Overall Height	64.45"	1637mm

* It is strongly recommended that the frame of the prefeeder be reinforced and/or additionally supported for elevator extensions of 54" or greater.

Headquarters
13129 Airpark Dr.
Suite 120
Elkwood, VA 22718
540.829.2564 t
800.368.3582 t
540.829.1726 f

Sales Office
1445 Brookville Way
Suite F
Indianapolis, IN 46239
317.322.0754 t
800.368.3582 t
317.322.0794 f

Manufacturing Office
291 Dillard Road
Madison Heights, VA
24572
434.929.4746 t
800.543.0915 t
434.929.4959 f

www.ShibuyaHoppmann.com | sales@ShibuyaHoppmann.com

Shibuya Hoppmann Corporation strives to improve its products and reserves the right to change or discontinue specifications & designs shown in this brochure without notice and without incurring obligation. Revised: 12/11.