

Product Overview:

The Capstar cap feeder is designed and engineered to feed and orient flat screw caps, tamper evident caps and other minimal featured products at speeds ranging from 40 to 600 parts per minute. Changeover from one cap to another takes less than five (5) minutes. The cleated elevator belt has a nominal cleat height of 2.00" and a cleat pitch of 4.00" allowing for maximum product loading. It is recommended that the cap diameter not exceed 3.50" with the standard belt, however, other belt sizes are available.

Part Number	FCCPSTRDSA (right hand unit)	FCCPSTLDSA (left hand unit)
Motor Style	DC	DC
Motor Voltage	90V	90V
Horsepower - Horizontal Belt	1/8hp	1/8hp
Horsepower - Elevator Belt	1/5hp	1/5hp

Standard Features:

- Polypropylene modular plastic belt
- Manually adjustable discharge height
- FDA approved white urethane cover continuous belt
- No tool changeover
- Small footprint
- Mounted encased controller
- Hopper agitator
- Casters and fixed feet

Available Options:

- Elevator extensions
- Continuous welded hopper seams
- Elevator/hopper covers
- Washdown motors

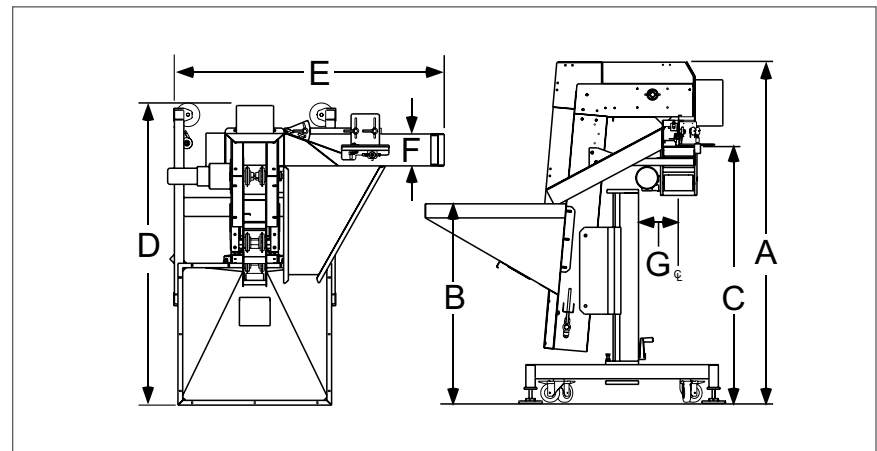

Product Specifications	ANSI	Metric
A Overall Height	65.13" - 81.13"	1655 - 2060mm
B Load Height	35.75" - 51.73"	908 - 1314mm
C Discharge Height	46.22" - 62.20"	1174 - 1580mm
D Overall Length	60.47"	1536mm
E Overall Width	54.00"	1371mm
F Belt Width	6.00"	152mm
G Conveyor Belt Center Line	7.00"	178mm

Headquarters
13129 Airpark Dr.
Suite 120
Elkwood, VA 22718
540.829.2564 t
800.368.3582 t
540.829.1726 f

Sales Office
1445 Brookville Way
Suite F
Indianapolis, IN 46239
317.322.0754 t
800.368.3582 t
317.322.0794 f

Manufacturing Office
291 Dillard Road
Madison Heights, VA
24572
434.929.4746 t
800.543.0915 t
434.929.4959 f

www.ShibuyaHoppmann.com | sales@ShibuyaHoppmann.com

Shibuya Hoppmann Corporation strives to improve its products and reserves the right to change or discontinue specifications & designs shown in this brochure without notice and without incurring obligation. Revised: 12/11.